

## ATMOTex Easyline

### Linear acoustics - perfectly assembled

Highly absorbing slat ceiling system for easy and fast self-assembly. The prefabricated slats are inserted into the System-sub construction. Due to the unique punching, the lamella is kept safe without further assembly effort. The quick-release trailer is connected to its usual system substructure.

Lamella width	10 mm
Lamella height	50 mm
Axle distance	50 mm
Slat length	2400 mm
Weight	1600 gr/m <sup>2</sup>
Fire rating (slats)	EN 13501-1 B-s1,d0
Color slats	grey / black / white
Carrying rail	Aluminum black
Height:	40 mm
Length:	2500 mm
Total weight:	approx. 2 kg/m <sup>2</sup>

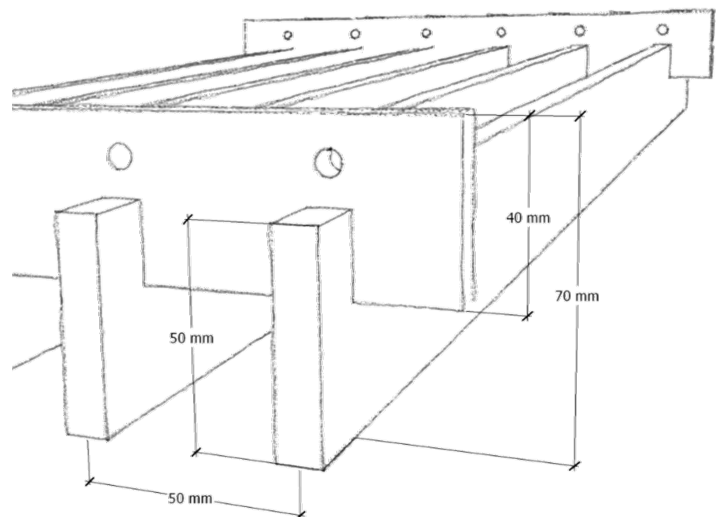

## ATMOTex Easyline

### Linear acoustics - perfectly assembled

Test setup

■ #50/10/10

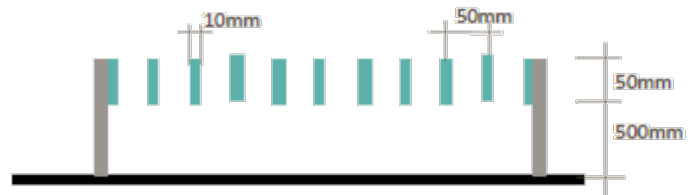

■ #50/10/10+10

